

SPEARHEAD

MULTICUT 460 PRO-LINE

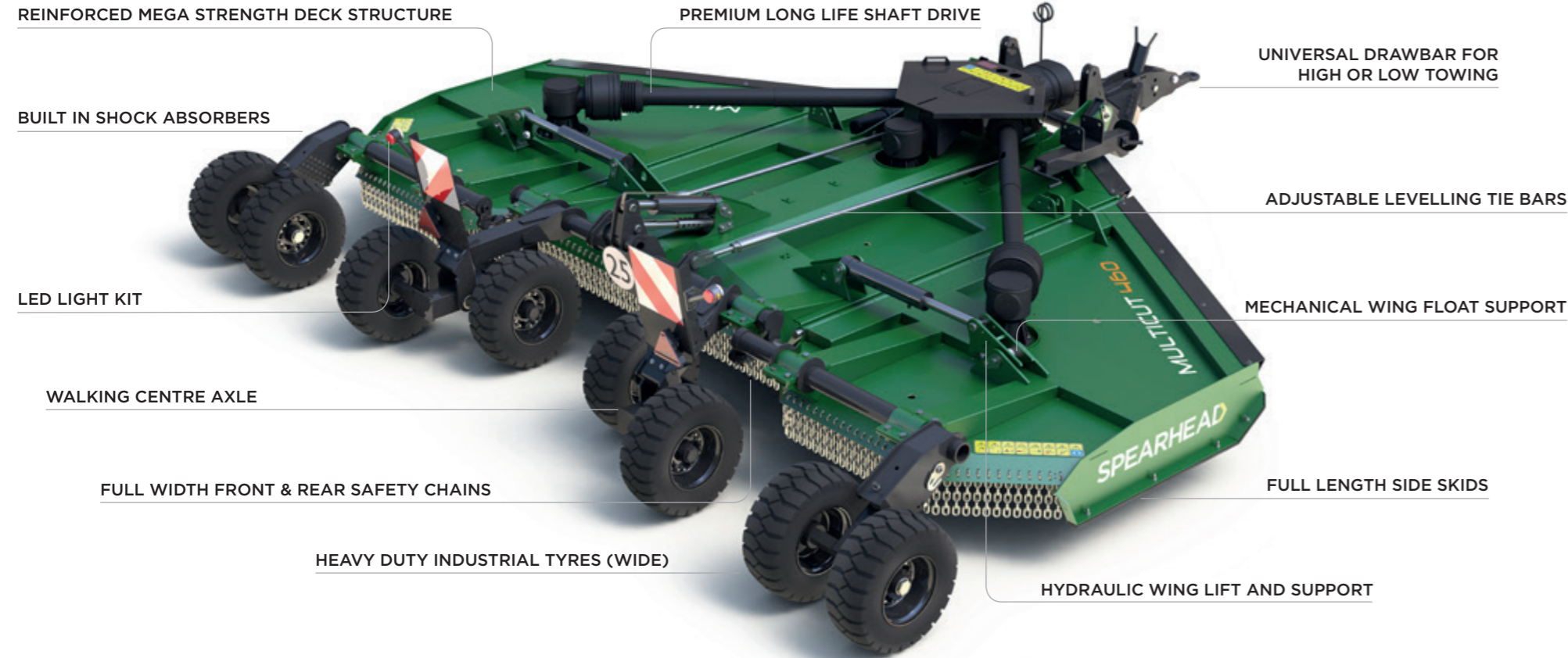



-  AGRICULTURE
-  PASTURE
-  LIGHT SCRUB
-  HEAVY SCRUB
-  AIRFIELD
-  HIGHWAYS
-  STUBBLE MANAGEMENT

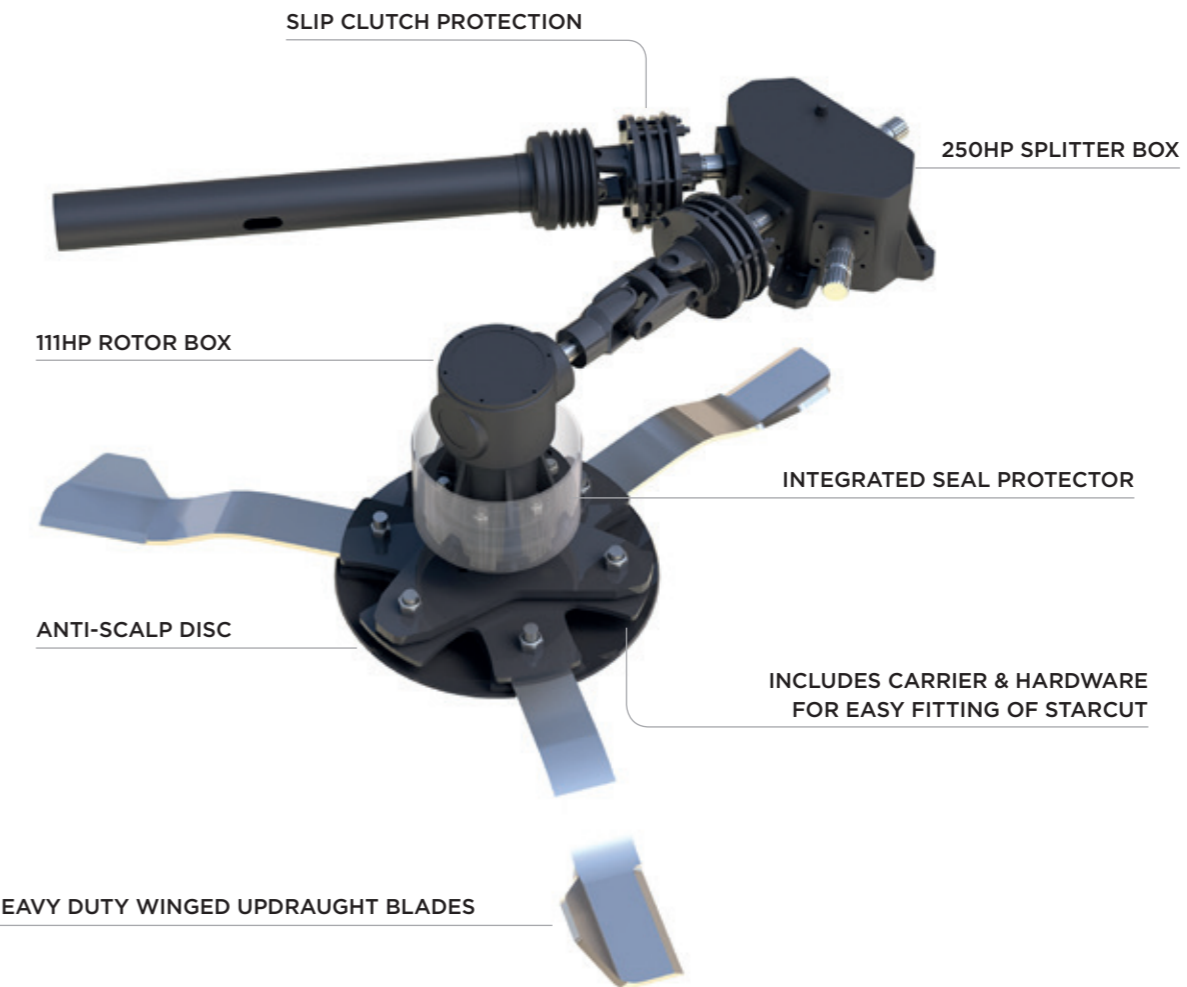

The Multicut 460 is now available in Proline specification! Action packed with all of the great features of the standard Multicut 460 – the standard bearer in rotary mowing equipment, the Proline machine features a suite of upgrades that further enhance reliability and performance.









A smooth ride is paramount with the standard walking axle design ensuring increased ground contour following and reduced shock loads through road transport.







Wider wheels are also fitted to add additional comfort but also to ensure reduced ground pressure in tough field conditions.

Similarly the machine is hardware equipped with a Euro LED light kit and importantly features the mounting system to allow the easy addition of 3 upper blades to upgrade each rotor to the STARCUT 6-blade system for increased mulching capability in applications such as Stubble Management.

MULTICUT 460 PRO-LINE

UNIT OPTIONS

 HP				 HP				
TRACTOR HP	PTO SPEED	TRANSPORT WIDTH	CUTTING WIDTH	GEARBOX RATING	NO. OF WHEELS	NO. OF ROTORS	NO. OF BLADES	CUTTING HEIGHT
70hp	540 - 1000rpm	2.70m / 106"	4.60m / 181"	250hp & 111hp	8	3	9	25 - 400mm 1" - 16"

						
6 BLADE KIT (FLAT BLADES)	HYDRAGAS SUSPENSION	6, 8 or 21 SPLINE PTO	SWIVEL TOWING EYE	K80 TOWING HITCH	WIDE WHEEL	540 RPM DRIVE SYSTEM

SPECIFICATION		MULTICUT 460 PRO-LINE	
Machine weight*	2500kg / 5512lbs	Gearbox oil capacity [rotor gearboxes (x3)]	2.1 litres / 3.7 pints
Hitch	Multi-positional drawbar	Deck construction	All welded construction
Cutting width	4.60m / 181"	Deck material thickness	6mm (1/4")
Working machine width	4.79m / 189"	Side skirt material thickness	5mm (3/16")
Transport machine width	2.70m / 106"	Skid construction	Replaceable bolt on skid shoes
Maximum working length	4.91m / 193"	Anti-scalp dish	6mm (1/4") round pan with blade holder bar
Transport length	4.83m / 190"	Blades (x9)	12mm (1/2") 30 Carbon Boron hardened and tempered. Free swinging high lift - low friction. Handed.
Deck height**	0.23m / 9"	Blade bolts	M24 C/W shank grade 8.8
Transport height	2.06m / 82"	Blade tip speed	80mps / 15748fpm
Cutting height	25mm - 400mm (1" - 16")	Driveline	ASAE Category 6
Cutting capacity	100mm / 4"	Driveline protection	2-way slip clutches on rotor gearboxes. Overrun on input shaft.
Recommended tractor HP	70hp / 52kW	Centre deck tailwheel mount assembly	Tubular welded walking axle
Wing working angles	45° up / 15° down	Wing deck tailwheel mount assemblies	Tubular welded standard axles
Power take-off speed	1000rpm (540rpm optional)	Tailwheels (x8)	21x9 14 PLY optional wider pneumatic tyre with steel hub
Gearbox [splitter]	Cast Iron housing	Front guard	Single chain guards on each deck
Gearbox [rotor gearboxes (x3)]	Cast Iron housing	Rear guard	Single chain guards on each deck
Input shaft	1" 3/8 Z21 or Z6 SFT 6/8 tractor end		
Gearbox lubricant	EP80-90W or GL-4 / GL-5 oil		
Gearbox oil capacity [splitter gearbox]	2.7 litres / 4.7 pints		

*With front and rear single chain guards ** Underside of deck to skid

SPEARHEAD

📍 Station Road, Salford Priors, Evesham, Worcestershire, WR11 8SW, England ☎ +44 (0)1789 491860

✉ enquiries@spearheadmachinery.com 📧 spearheadmachinery.com 🌐 SpearheadWorld



designed and built in
GREAT BRITAIN



Spearhead
is a member of the
Alamo Group

